



## Inductive sensor NBB10-30GM50-E0

- 10 mm flush
- Extended temperature range  
-40 ... +85 °C
- Extended operating voltage range
- Flexible use with versatile mounting opportunities



### Dimensions

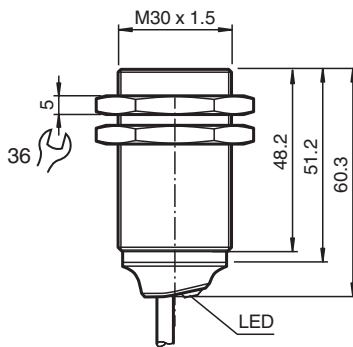

### Technical Data

#### General specifications

Switching function		Normally open (NO)
Output type		NPN
Rated operating distance	$s_n$	10 mm
Installation		flush
Output polarity		DC
Assured operating distance	$s_a$	0 ... 8.1 mm
Actuating element		mild steel, e. g. 1.0037, SR235JR (formerly St37-2) 30 mm x 30 mm x 1 mm
Reduction factor $r_{Al}$		0.5
Reduction factor $r_{Cu}$		0.42
Reduction factor $r_{304}$		0.74
Reduction factor $r_{Brass}$		0.52
Output type		3-wire

#### Nominal ratings

Operating voltage	$U_B$	6 ... 36 V
Switching frequency	$f$	0 ... 1100 Hz
Hysteresis	$H$	typ. 5 %
Reverse polarity protection		reverse polarity protected
Short-circuit protection		pulsing
Voltage drop	$U_d$	$\leq 1$ V

Release date: 2025-07-07 Date of issue: 2025-07-07 Filename: 326161-0165\_eng.pdf

Refer to "General Notes Relating to Pepperl+Fuchs Product Information".

Pepperl+Fuchs Group  
www.pepperl-fuchs.com

USA: +1 330 486 0001  
fa-info@us.pepperl-fuchs.com

Germany: +49 621 776 1111  
fa-info@de.pepperl-fuchs.com

Singapore: +65 6779 9091  
fa-info@sg.pepperl-fuchs.com

**PF** PEPPERL+FUCHS

## Technical Data

Operating current	$I_L$	0 ... 200 mA
Off-state current	$I_r$	max. 150 $\mu$ A
No-load supply current	$I_0$	$\leq$ 10 mA
Time delay before availability	$t_v$	$\leq$ 10 ms
Switching state indicator		LED, yellow
<b>Functional safety related parameters</b>		
MTTF <sub>d</sub>		1319 a
Mission Time (T <sub>M</sub> )		20 a
Diagnostic Coverage (DC)		0 %
<b>Conformity</b>		
PWIS conformity		VDMA 24364-C1/T100°C-W
<b>Compliance with standards and directives</b>		
Standard conformity		
Standards		EN IEC 60947-5-2
<b>Approvals and certificates</b>		
Protection class		II
Rated insulation voltage	$U_i$	36 V
Rated impulse withstand voltage	$U_{imp}$	500 V
UL approval		cULus Listed, General Purpose, Class 2 Power Source
CCC approval		CCC approval / marking not required for products rated $\leq$ 36 V
Marine approval		DNVGL TAA00003AK
<b>Ambient conditions</b>		
Ambient temperature		-40 ... 85 °C (-40 ... 185 °F)
Storage temperature		-40 ... 85 °C (-40 ... 185 °F)
<b>Mechanical specifications</b>		
Connection type		cable
Housing material		brass , white bronze coated
Sensing face		PBT , green
Degree of protection		IP65 / IP66 / IP67 / IP68
<b>Cable</b>		
Wire end ferrules		yes
Cable diameter		4.3 mm $\pm$ 0.15 mm
Bending radius		> 10 x cable diameter
Material		PVC
Color		black
Number of cores		3
Core cross section		0.34 mm <sup>2</sup>
Length	L	2 m
Mass		193 g
<b>Dimensions</b>		
Length		60 mm
Diameter		30 mm
Mounting		with nuts, M30
Tightening torque		$\leq$ 30 Nm
<b>General information</b>		
Scope of delivery		2 self locking nuts in scope of delivery

Release date: 2025-07-07 Date of issue: 2025-07-07 Filename: 326161-0165\_eng.pdf

Refer to "General Notes Relating to Pepperl+Fuchs Product Information".

Pepperl+Fuchs Group  
www.pepperl-fuchs.comUSA: +1 330 486 0001  
fa-info@us.pepperl-fuchs.comGermany: +49 621 776 1111  
fa-info@de.pepperl-fuchs.comSingapore: +65 6779 9091  
fa-info@sg.pepperl-fuchs.com

**PEPPERL+FUCHS**

**Connection Assignment**

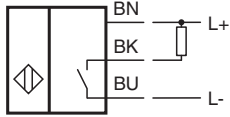

**Characteristic Curve**

Actuation by radial approach (standard target)

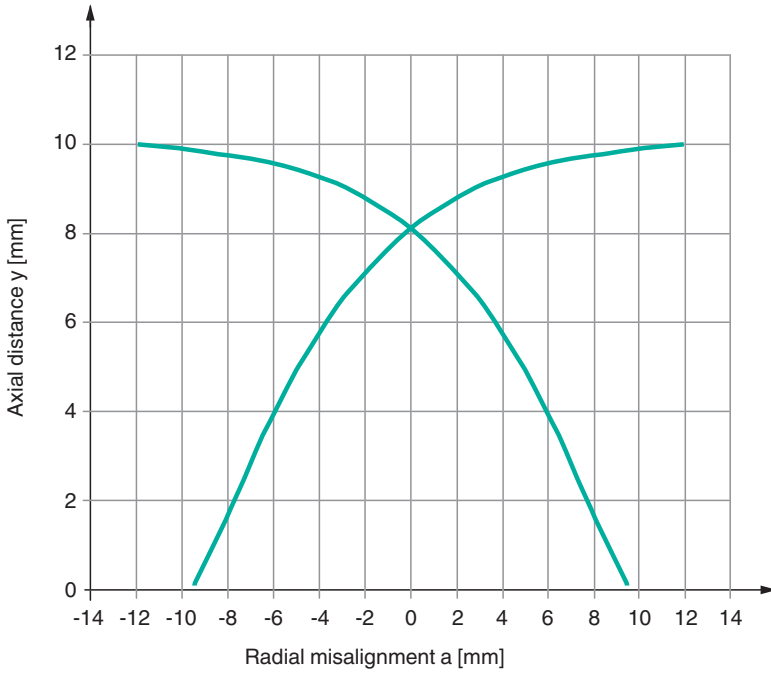

Switching distance depending on the actuating element

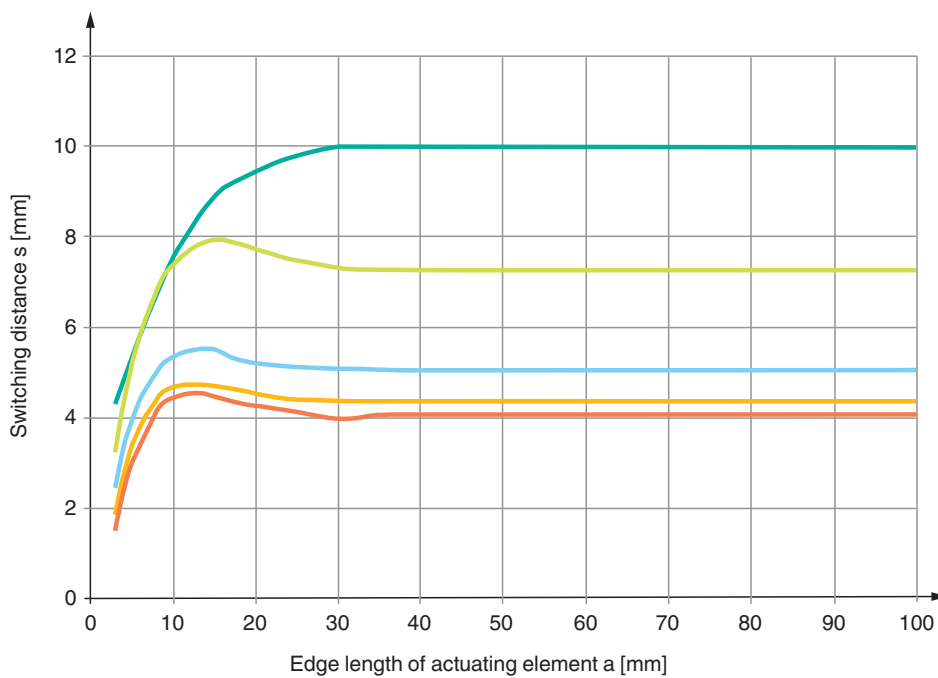

- Steel
- Stainless steel
- Brass
- Aluminum
- Copper

Release date: 2025-07-07 Date of issue: 2025-07-07 Filename: 326161-0165\_eng.pdf

Refer to "General Notes Relating to Pepperl+Fuchs Product Information".